

WSI-600 Person Weigher

Born Industrial . . . Raised Clinical



Reliable

Durable

Serviceable



WeighSouth
MEDICAL

A New Evolution in Health Scales



Quality manufacturing
and materials for durability



LCD Versatility
Column / Wall Mount

WeighSouth is proud to introduce the WSI-600 Person Weigher. Built with materials usually found in more expensive Industrial Scales the WSI-600 combines quality ISO Manufacturing with Sleek styling to produce a Person Weigher that is not only cosmetically pleasing but built Industrial Tough. Designed to meet the demands of high traffic weighing, the WSI-600 will return constant and accurate reading time and time again.

FEATURES

- Large 1" LCD for easy viewing
- Column Height adjusts from 29 to 50 inches high.
- WSI-600-NC has standard mounting bracket for easily attachment to Wall or Indicator will rest on table.
- Level bubble on base assures accuracy.
- RS232 Data Out
- AC or Battery powered. Unit comes standard with AC Adapter
- Tare and Zero Lock-out.

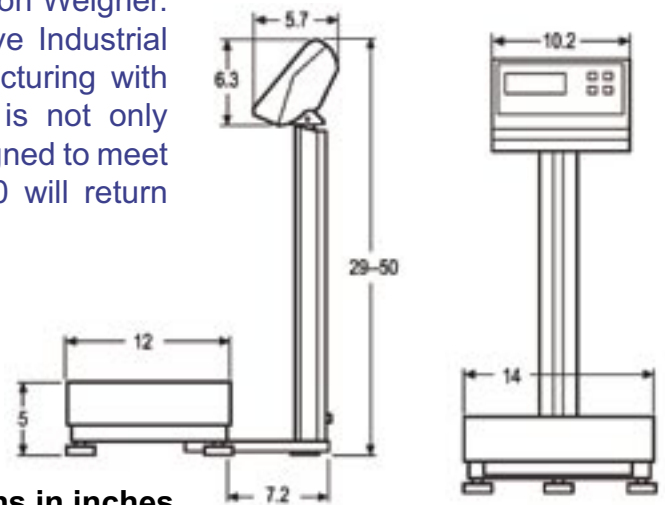

Dimensions in inches

Model	WSI-600	WSI-600 NC
Capacity	600 lb.	600 lb.
Readability	0.2 lb.	0.2 lb.
Display	Six-Digit 1 inch tall, high contrast, LCD	
Weight	36 lb.	27 lb.
Power	AC Transformer (included) or six "D" cell Battery life up to 500 hrs.	
Base Size	14" x 12" x 5"	
Standard Accessories	AC Transformer, Wall Mount, Installation Hardware	
Cable length	66"	
Data Output	RS-232	
Column	30"- 48" Adjustable	NA